

4

3

2

1

D

D

C

C

B

B

A

A

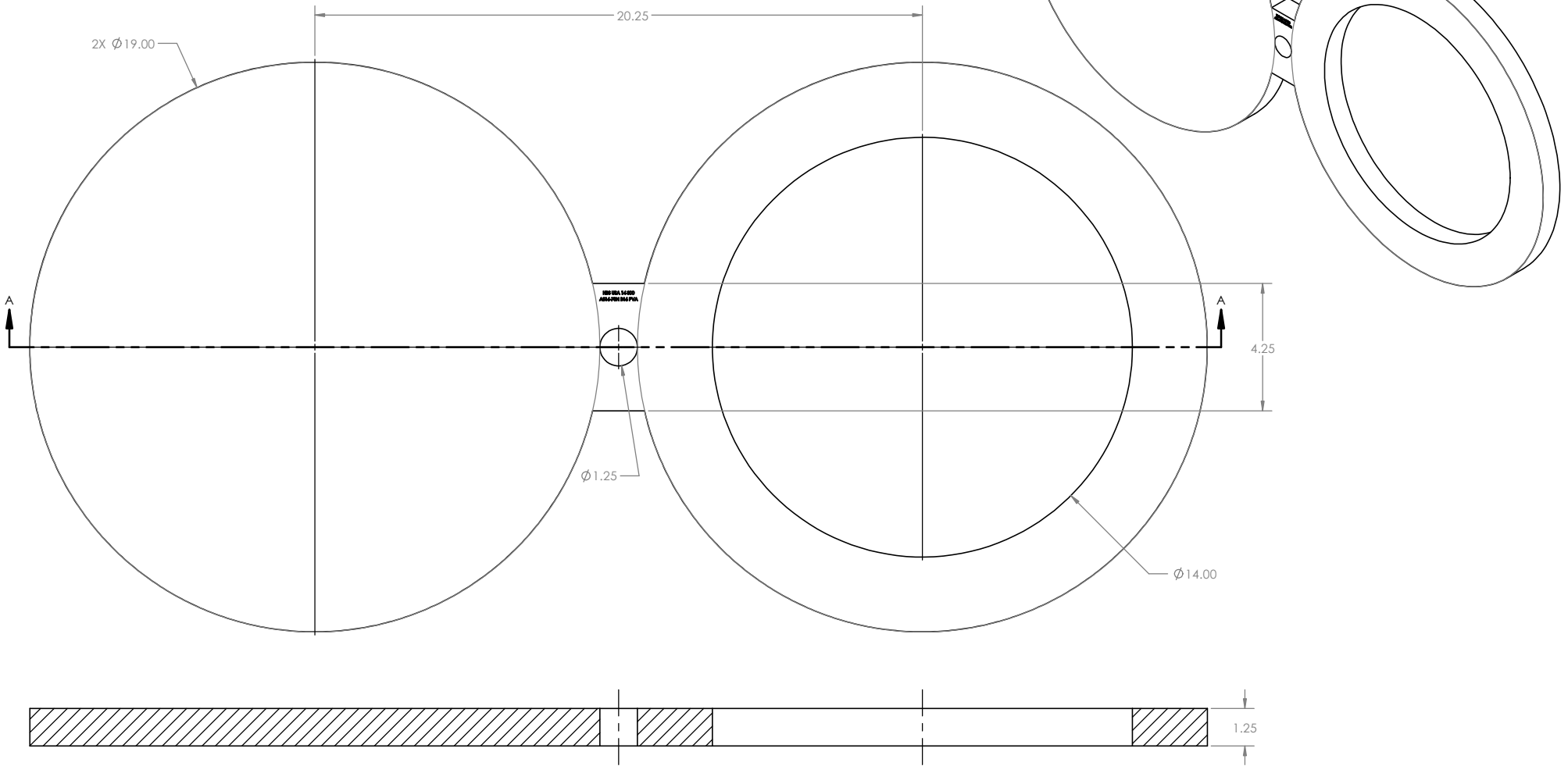

2X Ø19.00

20.25

4.25

Ø1.25

Ø14.00

1.25

SECTION A-A

DO NOT SCALE PRINT



UNLESS OTHERWISE SPECIFIED:  
 OUTSIDE DIAMETER: (+/-0.12)  
 INSIDE DIAMETER: (+/-0.12)  
 THICKNESS TOLERANCES (-ZERO +0.12)  
 ALL UNITS IN INCHES OR POUNDS

**HYDROBLIND**  
**-ISOLUTIONS**

MATERIAL: CUSTOMER REQUESTED

SHEET 1 OF 1

SURFACE FINISH: MACHINE OR MILL

DATE: 06/24/2020

DIMENSIONS & TOLERANCES TO BE IN ACCORDANCE WITH ASME B16.48

WEIGHT 146 lb

DRAWING TITLE: 14 CL 300 FIGURE 8 BLIND

SCALE 1:2.5

SIZE C

DRAWING NUMBER: 3SBU

REV 00

4

3

2

1